

# KOBEI

## FCL Pin & Bush Coupling

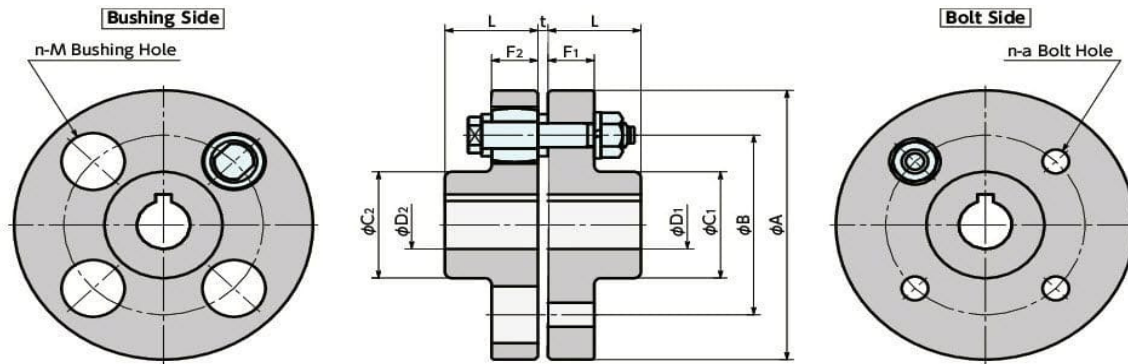

• The bolt hole positions are roughly arranged for the keyway.

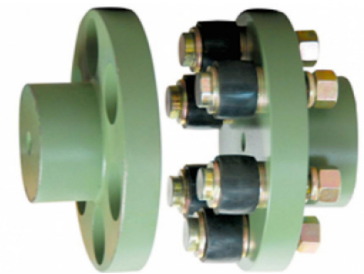
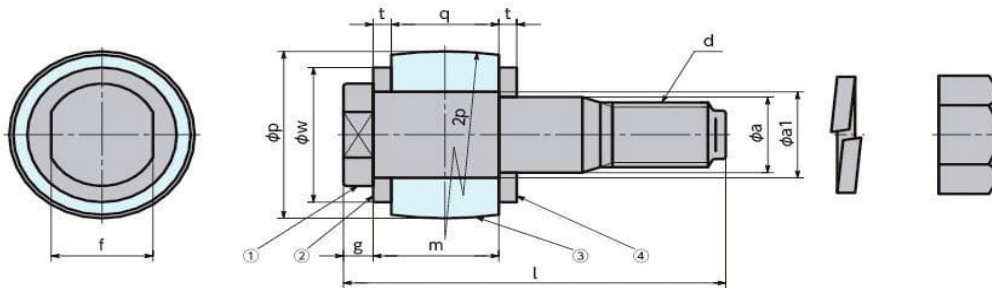

Size	Metal Hubs						Pin Code	Pin Qty	Bolt							Washer	Bush				
	Pilot Bore (mm)	Max Bore (mm)	Dimensions (mm)						Dimensions (mm)										t	p	q
			D1,D2	C1,C2	A	L			F1,F2	a1	a	f	g	m	l	w					
FCL-90	11	18	36	90	28	14	F1	4	9	8	10	4	17	50	14	2.5	18	14			
FCL-100	11	22	40	100	36	16	F2	4	12	10	13	4	19	56	18	2.5	22	16			
FCL-112	13	25	45	112	40	16		4													
FCL-125	13	28	50	125	45	18	F3	4	16	14	17	5	21	64	25	3	31	18			
FCL-140	13	35	63	140	50	18		6													
FCL-160	15	45	80	160	56	18		8													
FCL-180	15	50	90	180	63	18	F4	8	22.4	20	24	5	26.4	85	32	4	40	22.4			
FCL-200	21	56	100	200	71	23		8													
FCL-224	21	63	112	224	80	23	F5	8	28	25	30	6	32	100	40	4	50	28			
FCL-250	25	71	125	250	90	28		8													
FCL-280	34	80	140	280	100	28	F6	8	31.5	28	32	6	44	116	45	4	56	40			
FCL-315	41	90	160	315	112	28		10													
FCL-355	60	100	180	355	125	36	F8	8	40	35.3	41	8	61	150	56	4	71	56			
FCL-400	60	110	200	400	125	36		10													
FCL-450	65	125	224	450	140	36		12													
FCL-560	85	140	250	560	160	36		14													
FCL-630	95	160	280	630	180	36		18													